



Minimum Technical Requirements for the Renewable Energy Fund (REF)

All Rhode Island Renewable Energy Fund projects must demonstrate compliance with the Minimum Technical Requirements set forth in this document. These requirements are not intended to be all-encompassing, nor are they intended to be a substitute for engineering specifications, relevant codes and standards, or for safety requirements. Site-specific conditions and/or local regulations may stipulate additional requirements not contained in this attachment. Commerce RI reserves the right to withhold payment to any project that does not satisfy the Minimum Technical Requirements.

Table of Contents:

Solar Photovoltaic (PV):	2-4
Wind Technology:	5-6
Anaerobic Digestion:	7-10
Interconnection Methods for Solar PV Programs in RI:	11-13



Solar Photovoltaic (PV)

Required Inspection and Inspection Process

All installations are subject to a third-party inspection. Prior to the inspection taking place, the installer will be notified via email of the inspection. The installer's electrician should make all reasonable attempts to attend the inspection. An inspection report will be issued after each inspection. All corrections must be approved before grant payment is released.

Shading and Estimated Production Requirements

The PV project must be designed so that the estimated annual energy output for the PV project is at least 80% of the default optimal output for a fixed PV project of the same capacity, as estimated by PVWATTS or a similar tool. Optimal parameters for purposes of a PVWATTS estimate are:

- 1) 0.89 DC to AC derate factor,
- 2) 42 degree array tilt, and
- 3) 180 degree (True South) azimuth. PVWATTS is available at the following website:
<http://pvwatts.nrel.gov>.

The PV project must have a measured total solar resource fraction (TSRF) of 0.8 or greater and is subject to TSRF verification by Solmetric SunEye (or equivalent shade measurement tool) during onsite inspection. TSRF is a measure of the actual expected irradiance divided by the total irradiance available to a system with optimal siting characteristics (tilt, azimuth, etc.). Note that shading losses are incorporated into the TSRF and that a low TSRF can be the result of shading, non-ideal orientation, or both. When measuring TSRF, applicants must take measurements at all four corners of each proposed array location. The TSRF for each array is the mean of the readings taken at each of the four corners of the array. The overall TSRF is a weighted average of the individual array TSRF values, weighted by nameplate capacity. For example, a system with two arrays:

- Array 1: TSRF=90%, Capacity=5kW
- Array 2: TSRF=70%, Capacity=6kW

This system would have an overall TSRF of $(0.9)(5kW) + (0.7)(6kW)$ divided by 11kW, or 0.79, and would therefore be ineligible for an incentive.

Commerce RI has approved the Solmetric SunEye and Solar Pathfinder shading tools as program-compliant means of measuring and reporting TSRF for project applications. Helioscope, Bright Harvest and Aurora shading tools are also approved provided they utilize a method that measures onsite obstructions. All other methods must be proposed to, and approved by, Commerce RI prior to submitting an incentive application. All shading reports edited to indicate the future removal of obstructions must submit proof of such removal.

Installation Requirements

All installations must follow the most **current adopted edition of the National Electrical Code** with the following changes, as noted below. In all cases where manufacturer instructions, third-party

guides/handbooks, or other materials contradict the most current edition of any local, state, or federal code, the applicable code shall take precedence over such materials.

- Twist-on wire connectors (wire nuts) shall not be used in any outdoor enclosure unless listed to UL 486D for use in damp/wet locations. Proof of listing will be required during inspection if applicable. (See Article 110.28 for more information)
- Interconnections on the utility side of service disconnecting means are considered a second “set” of service-entrance conductors as permitted in Article 230.40, Exception 5 and 230.82(6), but not considered an “additional service.”
 - PV system disconnect must be suitable for use as service equipment, in accordance with Article 230.70.
 - Utility conductors must always be on the line terminals of the disconnect, otherwise fuses will remain energized when disconnect is in open (off) position.
 - Article 230.79(D) requires a minimum rating of 60A, OCPD AIC rating follows 110.9 & 110.10.
 - Service-entrance conductor set required to be sized to disconnect rating, in accordance with Article 230.42(B).
 - Wiring methods for conductors on the utility side of disconnect shall follow Article 230.43.
- Residential installations of ground- and pole-mounted arrays must have a disconnect switch as described in Article 690.17 exception two, located at the array to isolate all DC current carrying conductors. This is not required where the ground- or pole-mounted array consists entirely of AC modules, DC-DC converters (optimizers), or microinverters.
- Areas where wiring passes through ceilings, walls, or other areas of the building must be properly restored, booted, and sealed. Thermal insulation in areas where wiring is installed must be returned to “as found or better” condition.
- Commerce RI requires that photos be taken of the following system components for all rooftop solar arrays, including: array and PV modules, DC disconnect, string inverters (including transformerless units), microinverter/DC optimizer, AC disconnect/AC combiner, and interconnection (supply side and load side). These photos shall be kept on record with the primary installer and made available to Commerce RI upon request.
- An owner’s manual of operating and maintenance instructions must be provided to the PV project owner and preferably also posted on or near the PV project. The owner’s manual should include manufacturer’s specifications, serial numbers, warranty policies, etc.
- Owners must be provided with, at minimum, a basic training orientation that includes maintenance instructions, troubleshooting, meter reading, and electric production reporting instructions.
- Solar PV projects designed to be installed on pitched, non-flat roofs, are required to have an azimuth that is the same as the roof azimuth, in order to be eligible to receive a rebate.

Roof Requirements

PV arrays shall not be installed on any roof that is expected to be replaced within 10 years, or that contains damage that may require repair or early replacement.

Common Installation Violations

- Indoor-rated twist-on wire connectors (wire nuts) shall not be used in outdoor enclosures. Article 110.28 indicates this area can be a damp or wet location, and such installation may violate the listing of the product, see also Article 110.3(B).
- NM-B cable (Romex®) shall not be sleeved in outdoor raceways. Article 300.9 defines the interior of such raceways as a wet location and Article 334.12(B)(4) prohibits this cable to be installed in a wet location.
- Article 300.7(A) requires raceways passing from the interior to the exterior of a building be filled with an approved material to prevent the circulation of warm air to a colder section of the raceway.
- Article 250.24(A)(5) prohibits a grounded (neutral) conductor to be connected to ground at any location downstream of the service disconnecting means. Common violations include this connection in a PV meter enclosure or an AC combiner panelboard.
- Terminal ratings and conductor size/limitations must be followed per Article 110.3(B). Common violations include multiple conductors under a terminal listed for a single conductor, or conductors undersized for the terminals, such as inside a meter enclosure.



Minimum Technical Requirements for the Renewable Energy Fund

Wind Technology

Estimated Production Requirements

Estimated annual electricity generation for wind energy projects must be made using a bin analysis method, such as NREL's WindCAD model or an equivalent tool that combines a wind speed probability distribution with a wind turbine power curve and includes relevant adjustments for local terrain, vegetation, and turbine operational characteristics. Key inputs shall include:

- Wind Speed: Annual mean wind speed shall be obtained from a reputable data source with a minimum spatial resolution of 2.5km x 2.5km
- Anemometer Height: The reference height accompanying the annual mean wind speed. Standard heights include 30m, 50m, and 80m
- Wind Shear: The wind shear is used to adjust wind speeds to match the proposed tower height and reflect, generally, how rough the local terrain is. Commerce RI recommends the following wind shear values based on general nearby terrain:
 - Grass: 0.15
 - Cropland/agricultural: 0.22
 - Scattered trees and hills: 0.29
 - Sparse forest/buildings: 0.34
 - Dense forest/urban setting: 0.44
- Tower Height: The proposed height of the tower
- Adjusted Hub Height: The anticipated hub height of the wind turbine, less the mean canopy height, where mean canopy height is the average height of densely packed obstructions within 10 rotor diameters of the tower location. For example, a 140ft tall tower surrounded by 40ft average canopy height forest would have an adjusted hub height of 100ft. Adjustments to canopy height based on packing density may be made at Commerce RI's discretion.

Commerce RI also recommends including a wind rose, to indicate the directionality of the site wind resource.

For projects with rated generator output, at 11 m/s, greater than 1MW must estimate annual generation based on at least 6 months of onsite meteorological data and a measure-correlate-predict (MCP) analysis correlating short-term monitoring with long-term local weather conditions.

Installation Requirements

All wind energy projects must be installed per Article 695 of the current edition of the National Electric Code, as well as all relevant equipment installation instructions and engineering specifications. In addition, Commerce RI has the following specific requirements:

- The bottom of the rotor swept area must be at least 30ft above all surrounding obstructions within 500ft of the tower base
- Applicants seeking grant funding for wind energy projects installed on parcels less than 5 acres in size shall include signed letters of support from all abutting neighbors as attachments to the grant application. These letters must indicate that neighbors have been made aware of all possible acoustic and aesthetic impacts and have no opposition to the proposed project.

Common Installation Violations

- Wind energy projects are frequently sited incorrectly with relation to the available site wind resource. It is important to use the most accurate wind data possible and to position the wind turbine to minimize obstructions to wind flow. Though this is particularly important in the windward direction, obstructions downwind of the wind turbine can also negatively impact the available wind resource.
- All towers and associated equipment must be properly grounded to minimize the risk of lightning strikes



Minimum Technical Requirements for the Renewable Energy Fund

Anaerobic Digestion

Estimated Production Requirements

Installers shall comply with the following production/yield validation methods:

Biogas production estimates will be conducted using the following calculation, unless REF approves an alternative method.

$$Annual\ Biogas\ (ft^3) = \frac{A \times B \times C \times D \times E \times 365\ days}{F}$$

Where:

- A Number of animals (Agricultural) or gallons of influent per day (industrial)
- B Pounds of organic material per day
- C Percentage of organic material collected in influent (less spillage and other losses)
- D Digester efficiency
- E COD¹ conversion factor (ft³ methane per pound of organic matter)
- F Percent methane in biogas

Because the energy production from anaerobic digestion is highly dependent on feedstock, operating conditions and selected digestion process, the feedstock to the AD system should meet the following values for methane gas production:

Methane Gas Production by Feedstock*

Feedstock	Total Solids (%)	CH ₄ Yield (ft ³ per pound)
WWTP sludge	**	**
Livestock manure	3-12	0.224-0.288
Food waste	10-30	0.962-1.754
Organic MSW	15-35	0.8-1.515

* adapted from Cenex, June 2009

** For WWTP Sludge the following table applies:

CH₄ Yield

¹ Chemical Oxygen Demand is a measure of the amount of oxygen required to aerobically digest a substance into CO₂ and H₂O and is used to measure the heat content available from the reverse reaction converting methane and oxygen into water, carbon dioxide, and energy.

Feedstock

Primary Sludge
Secondary
Sludge

(f ³ per pound volatile solids)
5-6.25
3.03-3.846

* adapted from IEA Bioenergy, Bachmann et al., 2015

Biogas generation shall be converted into energy savings metrics such as electricity (kWh) or natural gas (therms) savings. Ultimately, the energy savings to be evaluated will be driven by a range of factors but the primary output, biogas, will be converted to the appropriate units for evaluation purposes.

The efficiency of the overall AD system depends on the selected energy conversion technology. The selected technology energy efficiency values must fall within these ranges noted in the table below, unless the applicant can supply sufficient justification for an alternative assumption:

Technology	Net Electrical Efficiency		Net Thermal Efficiency		Size Range kW
	Range %	Typical %	Range %	Typical %	
Internal Combustion Engine	25 – 45	33	40 – 49	40	50 – 5K
Internal Combustion Engine – Lean Burn		37			
Gas Turbines	23 – 36	30	40 – 57	40	250 – 250K
Microturbines	24 – 30	27	30 – 40	35	30 – 250
Steam Turbine	20 – 30	25	20 – 45	45	500 – 1,300K
Stirling Engine	25 – 30	27	45 – 65	60	1 – 50

Reprinted with permission from the Water Environment Federation, MOP 32, 2009.

Installation Requirements

Depending on the proposed technology (low or high solid, single stage/multistage, mesophilic, thermophilic), the anaerobic digestion system must be installed in accordance with the manufacturer instructions and design engineer specifications.

- For the design of the digester and gas components, installer shall provide adequate safety measures and install components in accordance with standard engineering practice for handling a flammable gas. Safety and best practice standards should comply with NRCS Practice Standard 366, Anaerobic Digester².

² <https://efotg.sc.egov.usda.gov/references/public/NY/nyps366.pdf>

- An owner’s manual of operating and maintenance instructions must be provided to the AD project owner and preferably also posted on or near the AD project. The owner’s manual should include, at a minimum:
 - Manufacturer’s specifications, serial numbers, and warranty policies
 - Proper loading rates of the digester and total solids content of the influent
 - Operating procedures for the digester
 - Description of the planned startup procedures, normal operation, safety issues, and normal maintenance items
 - Instructions for safe use and flaring of biogas

Owners must be provided with, at minimum, a basic training orientation that includes maintenance instructions, troubleshooting, meter reading, and reporting instructions.

System Requirements

All installations must follow the most **current edition of the National Electrical Code** with the following additions as noted below. In all cases where manufacturer instructions, third-party guides/handbooks, or other materials contradict the most current edition of any local, state, or federal code, the applicable code shall take precedence over such materials.

- Installer shall measure, track, and document the feedstock type and quantity used in the digester design. Digester design must take into account varying feedstock properties. Depending on the system design, extraneous material may need to be removed, reduced, or otherwise handled.
- Digester cover, materials, anchorage, and appurtenances shall be designed to capture and convey biogas to the gas collection system. The digester cover and materials shall meet the requirements of NRCS Practice Standard 367, Waste Facility Cover³.
- Above or below grade tanks must be equipped with an overhead exhaust/ventilation system to capture gaseous emissions and route them to an odor control system.
- All odorous areas should be vented to appropriate abatement. Acceptable abatement treatments include: biofilters, carbon filters, chemical scrubbers, and thermal oxidizers.
- Emission Controls:
 - Nutrient Management Plans must account for how all waste components will be utilized. All participating farms must follow a nutrient management plan that complies with the 2015 NRCS 590 Nutrient Management Standard.⁴
 - Installers or operators should implement an environmentally responsible digestate management plan.

³ https://www.nrcs.usda.gov/wps/PA_NRCSConsumption/download?cid=nrcseprd340709&ext=pdf

⁴ https://www.nrcs.usda.gov/Internet/FSE_DOCUMENTS/stelprdb1192371.pdf

Installers must install and maintain a gas meter and provide measurements of total biogas produced, including the amount of methane produced⁵. The amount of methane content in biogas may vary, but typically ranges from 60%-70%.

Common Installation Violations

As noted above the design and construction of anaerobic digestion depends on the process configuration.

The construction contractor/installer must comply with all local permit requirements.

⁵ An example of one meter that may be suitable for automatic methane monitoring:
<http://www.co2meter.com/products/50-co2-100-ch4-meter-nema4>

Interconnection Methods for Solar PV Programs in Rhode Island

Based on the 2014 National Electrical Code (NEC)

Introduction

Rhode Island currently has two frequently-used solar PV incentive programs. The Renewable Energy Fund (REF) program, overseen by the Rhode Island Commerce Corporation, is a grant program for “behind the meter” PV installations. The Renewable Energy Growth (REG) Program is a tariff-based program overseen by National Grid; this program is strictly for an interconnection on the utility side of any existing meter. A PV installation may receive an incentive from only one program; the program-specific interconnection requirements must be adhered to ensure incentive eligibility.

Rhode Island REF Program Interconnection

The Rhode Island REF program consists of conventional “behind the meter” PV installations. Upon approval, the utility will replace the existing electric meter, with a NET meter that is capable of recording electricity usage in both directions. At the end of the billing month, the customer pays the net amount, which may be a bill credit if the PV system produced more electricity than the property consumed. Article 705.12 of the NEC identifies two possible interconnection locations: supply-side, and load-side of the main service disconnecting means.

Supply-Side Connection

Article 705.12(A) of the NEC provides allowance and guidance for interconnections on the utility side of the service disconnecting means. References are made to Article 230, which are requirements for electrical services. For the REF program, this interconnection would be between the service disconnecting means (main breaker) and utility meter. See the center red arrow of Figure 1.

Load-Side Connection

Article 705.12(D) of the NEC provides allowance and guidance for the various types of connections on the load side of the service disconnecting means.

The two primary types are backfed circuit breakers in an existing panelboard and feeder taps. The lower red arrow of Figure 1 shows a backfed circuit breaker. Article 705.12(D)(2)(3) outlines the specific requirements for this type of interconnection, including consideration for existing equipment and overcurrent protection size as well as specific location in the panelboard. Alternatively, Article 705.12(D)(2)(1) provides requirements for feeder tap interconnections, often located between the service disconnecting means and a sub-panel.

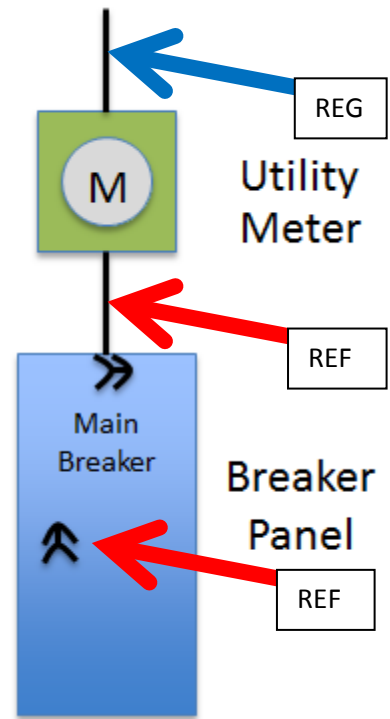

Figure 1: Interconnection Locations for Programs in RI

Rhode Island Renewable Energy Growth Program Interconnection

The Rhode Island Renewable Energy Growth (REG) program is a tariff-based incentive program hosted by National Grid. Because of the very nature of the program, the PV system must be connected to a dedicated utility meter to properly measure system output, as outlined by Section 4 of the REG Program Tariff document (RIPUC No. 2151). Unlike conventional interconnection methods, the PV system for this program is a new “tenant” on the property. With an existing electrical service, the PV system must be connected to the utility side of the existing electric meter, as shown by the top blue arrow in Figure 1. Furthermore, Figure 2 illustrates the addition of the new dedicated electric meter to the existing electrical service. Because this is considered a supply-side connection in the NEC, the requirements of Article 705.12(A) and 230 must be followed. National Grid¹ currently allows two different methods to install the new REG PV meter.

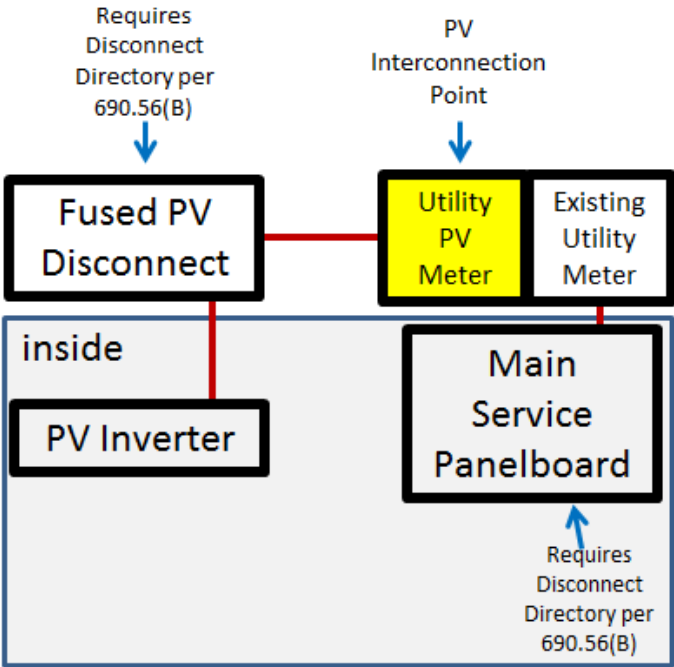

Figure 2: PV Interconnection as New “Tenant” in Existing Electrical Service

Multi-Gang Meters

For both overhead and underground electrical services, the existing meter enclosure can be replaced with a multi-gang enclosure to accommodate the new “tenant” at this location. Figure 3 shows an example of the new multi-gang meter enclosure method. This is currently the only allowable option for underground electrical services.



Figure 3: New Multi-Gang Meter Enclosures in Existing Underground (left) and Overhead (right) Electrical Services

¹ https://www9.nationalgridus.com/narragansett/business/energyeff/4_interconnection-process.asp

Separate Service to Each Meter

For overhead electrical services, an alternative to replacing the existing meter, is a connection at the service point with a parallel service drop to the new REG meter. Figure 4 shows this alternative connection method with the PV system components. This method does not alter any existing electrical components, however consideration should be taken for the overhead splice methods that will likely be exposed to the weather.



Figure 4: New REG Electrical Service in Parallel with Existing